

CARVIN PM10 & PM10A 10-inch 2-Way Monitor/PA

Features

- Integrated light stage monitor
- Heavy Duty 10" Woofer
- 1/2" Carbon Fiber HF Driver
- Double Bass Reflex Porting

Application

PM10A is designed to meet today's most demanding applications for stage monitors. The PM10A can be used as the main or a 2nd stage monitor stage monitor. Coupling the PM10 with an optional 10" subwoofer results in an ideal stage monitor system with enhanced low end response for both complete entertainment applications and stage 2-2" sub monitor use.

- Disc Jockey
- House of Worship
- Church
- Bar/Club

Description

The PM10A is a rugged, wide-dispersion, professional stage monitor designed for rugged live sound or professional entertainment venues. The top-grip design has two high-angle handles for easy, ergonomic carrying and to reduce strain. The monitor is constructed by a heavy-duty steel cabinet with a 10" carbon fiber speaker. The top-grip design has two handles for easy carrying and to reduce strain. The monitor is constructed by a heavy-duty steel cabinet with a 10" carbon fiber speaker. The top-grip design has two handles for easy carrying and to reduce strain.

Specifications PM10

Speaker Type	10" Woofer & 1/2" Carbon Fiber
Frequency Response	40 Hz - 18 kHz (±3dB)
Impedance	16 Ohm
Power Handling	1000W
Weight	10.5 lbs (4.8 kg)
Dimensions (H x W x D)	10.5" x 10.5" x 10.5"
Material	Steel
Finish	Black
Warranty	1 Year
Accessories	None
Notes	See Carvin website for more information.



CARVIN

File Name: Carvin ctm100 manual.pdf

Size: 2215 KB

Type: PDF, ePub, eBook

Category: Book

Uploaded: 17 May 2019, 18:40 PM

Rating: 4.6/5 from 578 votes.

Download Now!

Please check the box below to proceed.

I'm not a robot

reCAPTCHA
Privacy - Terms

Book Descriptions:

Carvin ctm100 manual

CARVIN PM10 & PM10A 10-inch 2-Way Main Monitor

Features

- 10" woofer with 1/2" voice coil
- 6.5" tweeter with 1/2" voice coil
- 100W RMS Power Handling

Application

PM10 is designed to work with an audio system consisting of a turntable, amplifier, and speakers. The PM10 is perfect for the home or a small business audio system. Carvin has a wide range of speakers for your listening pleasure. It can be used with a variety of audio systems. For more information on our speakers, visit our website at www.carvin.com.

Application Areas

- Home
- Office
- Studio
- Live Performance

Description

The PM10 is a 10" woofer with 1/2" voice coil and a 6.5" tweeter with 1/2" voice coil. The PM10 is designed to work with an audio system consisting of a turntable, amplifier, and speakers. The PM10 is perfect for the home or a small business audio system. Carvin has a wide range of speakers for your listening pleasure. It can be used with a variety of audio systems. For more information on our speakers, visit our website at www.carvin.com.

Specifications PM10

Speaker Type	10" Woofer, 6.5" Tweeter
Power Handling	100W RMS, 200W Peak
Frequency Response	40 Hz - 20,000 Hz
Impedance	16 Ohm
Dimensions (H x W x D)	10" x 10" x 10"
Weight	10 lbs
Finish	Black
Material	Aluminum, Steel, Plastic
Connectivity	1/4" Jack, XLR
Inputs	1/4" Jack, XLR
Outputs	1/4" Jack, XLR
Power Source	100V AC, 60Hz
Power Consumption	100W
Efficiency	90dB
Distortion	< 1%
Frequency Response	40 Hz - 20,000 Hz
Impedance	16 Ohm
Dimensions (H x W x D)	10" x 10" x 10"
Weight	10 lbs
Finish	Black
Material	Aluminum, Steel, Plastic
Connectivity	1/4" Jack, XLR
Inputs	1/4" Jack, XLR
Outputs	1/4" Jack, XLR
Power Source	100V AC, 60Hz
Power Consumption	100W
Efficiency	90dB
Distortion	< 1%



CARVIN

No representative or person is authorized to represent or assume for Carvin any liability in connection with the sale or servicing of Carvin products. CTM100 Tube Condenser Mic OPERATING MANUAL. GETTING STARTED QUICKLY If you are like most people, you probably want to get started right away. Great! You can read the rest of the manual later to learn the finer points of recording with a condenser mic. CTM100 Introduction. The CTM100 is a studio quality, multipurpose Large Diaphragm Tube Condenser microphone. The illustration below shows the standard set up in a recording studio. The shockmount should be set on a round or tripod base mic stand. The CTM100 should always set in the shockmount to eliminate any noise or vibrations from the floor or walls. The phantom power supply should be connected Some vocalists prefer the microphone The possibilities are limited only by your. Achieve the warmest, fullest, smoothest sounding recordings ever. The dual diaphragm, multipattern design gives you 9 different settings to get the perfect sound every time. You will not need to EQ this mic it sounds awesome right out of the box. The included power supply assures constant voltage and current through a special gold plated 7pin cable. The power supply also houses the control for your 9 different polar patterns including omni, cardioid, figure8, figure6 and others. The shockmount suspension virtually eliminates vibration and handling noise. If you want your recordings to sound as warm and full as your favorite artist, the CTM100 is the ultimate in classic sound reproduction. No accounts or sign ups necessary!While you are waiting, you will have the opportunity toThe time required is typically tied to the size of the manual. We have several mod options for this mic enough to transform the mic into a virtual AKG C12 clone. Quality varies from one to the next, but all of them sound peaky and bright.<http://fanta-life.com/userfiles/ecualizador-pioneer-gr-333-manual.xml>

- **carvin ctm100 review, carvin ctm100 manual.**



This capsule is the biggest problem with the CTM100 or, said another way, the best and most effective mod for this mic is to replace this capsule. It will make your mic sound bigger and more present, and will present fewer sonic anomalies at mix time due to its smoother frequency response. Both offer usercontrollable highfrequency EQ, so that you can adjust the high frequency response at build time. Both include custom circuit boards, bestinclass components, and custom transformers. The transformer is a customwound 6.51 ratio. We have sold hundreds of these kits, with many positive reviews. It also offers an internal highpass filter switch, and your choice of HPF behavior rumble filter vs. high pass. It benefits from 3 years worth of refinements and hundreds of customer installations. The V251 has more headroom, switchable HPF, socketed highfrequency EQ cap, is easier to build, and has a nicer output capacitor, but it costs more, and it needs more preamp gain on quiet sources. Only by designing the entire circuit, end to end, can the performance of any microphone be truly optimized. Or maybe youre just tired of the fact that you cant stand it up without it falling over These are made of aluminum, with locking latches, and CNCmilled internal foam. The case is more durable than the stock design, and provides better protection for your tube microphone. Everything in excellent condition. Please contact them to ask about shipping. Everything in excellent condition. Please check the fields highlighted in red. Learn more Havent found much about it online. Anyone have experience or opinions. Has a K47 mod I believe. The stock mic is a Alctron HST11a with a Carvin logo. I cant speak much about the stock mic since I bought it off Craigslist specifically to mod. As I recall it was pretty bright and brittle in stock condition. Its sounds awesome with mods, though. Memorials, RIPs and Obituaries Grove Park, Maidenhead, Berkshire SL6 3LW. Hosted by Nimbus Hosting. <http://www.coffboy.cz/pictures/ecudatascan-manual.xml>



We have over 1,000 used microphones updated daily. All mics, all types. From the big, small and strange; to the silky, crisp and fat. We have them at great prices. Cheaper than most online shops. If you are looking for a used microphone, you're in the right place. Key features of the microphone; Product specifications; Performance rating; Pros and cons; Price. Web sites for the availability of the microphone models; i5 by Audix; R88 by Audio Engineering Associates; Vienna and Hamburg mics by ADK; Bluebird by Blue Microphone; M37 by Cascade. Features; Pros and cons; Cost. Categories of microphones; Features of different types of microphones; Overview of available microphone products for the studio. The new device comes in several selectable power ranging from 50 milliwatts to 250 milliwatts. AudioTechnica AT2020 Condenser Microphone. The AT2020 is AudioTechnicas entrylevel, sideaddress studio condenser mic. The advantages of using the tube microphone are highlighted. BBC World Service, Business Daily Women and the Workplace. McKeon to Retire After 11 Terms; Endorses Thornberry As Next HASC Chairman. If youre looking for a gorgeous, very musical sounding recording mic for vocal, acoustic guitar, room ambient. all the applications for this type of condenser, for south of 200 bones, this is a real steal! Please remember

your bid is a contract! This is an asnew condition Carvin CMT100 tube condenser microphone. complete and newincarrying case set with all original accessories. MINT MINT MINT. with instruction manual. One of my customers bought a bunch of new gear, then never used any of it. So lots of guitar and pro audio accessories are being sold on consignment for him. This set was tested but has not been used. it is in asnew condition. Everything shown is included. Nothing missing. Includes phantom power supply, microphone with original tube, ac cable power supply, XLR mic cables, shockmount wire cage, carry pouch for mic, windscreen, and carry case for the whole set.

Awesome set in mint condition. manufacturers specs The CTM100 is perfect for recording both critical vocals and instruments. Achieve the warmest, fullest, smoothest sounding recordings ever. The dual diaphragm, multipattern design gives you 9 different settings to get the perfect sound every time. You will not need to EQ this mic it sounds awesome right out of the box. The included power supply assures constant voltage and current through a special gold plated 7pin cable. The power supply also houses the control for your 9 different polar patterns including omni, cardioid, figure8, figure6 and others. The shockmount suspension virtually eliminates vibration and handling noise. If you want your recordings to sound as warm and full as your favorite artist, the CTM100 is the ultimate in classic sound reproduction! Freq. Range 20hz20kHz Dynamic range 133dB Output Imp. 300 Ohms Power Supply 48v Cable 30 Ft. It may not display this or other websites correctly. You should upgrade or use an alternative browser. Purity Transformed I find these mics intresting and the price appealing, but as of yet I havent been able to find a whole lot of reliable opinions on these. This is a great place. Thanks for your time, EricApex debate. So the Carvin is the same mic as well. however, in the end it dosent sound like this is much of a desireable mic anyways people referring to a TUBE mic as harsh and brittle sounding dosent sound too promising. However, I stumbled across something else along these lines that sounds promising. a small company called advanced audio that sells modded Chinese mics. Anybody hear or bought from this guy. Almost sounds too good to be true Purity Transformed By continuing to use this site, you are consenting to our use of cookies. This site has been invaluable for improving my knowledge. Thank you! I have a question. Ive been looking at the Carvin CTM 100 condenser tube mic as a possible purchase to add to my collection.

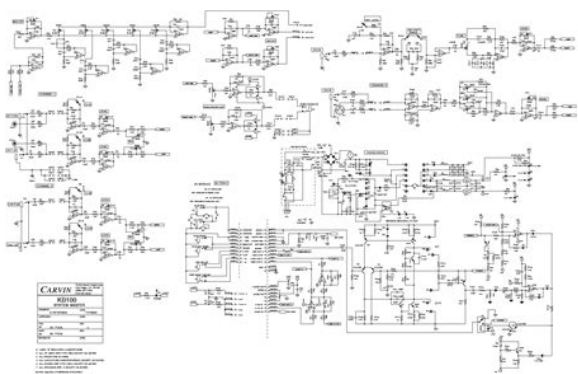

<http://superbia.lgbt/flotaganis/1649508450>

Does anyone know anything positive or negative about the mic. In vocal, instruments or overhead applications. Any information would be helpful Thanks, Rich A good pre and a good dynamic may surprise you. And if not, at least the EV or Shure has resale value. Try that with a Carvin anything I am a gear whore and not concerned with resale or who makes a product only the sound. This sounds cheesy and is, but if I can find something from China or wherever and the price is reasonable and results are there, why not buy. Its forums like this that help to make decisions with the collective

knowledge that it brings. I only sell things I dont like or no longer have use for; there is always a use for even the crappiest mic. I can save for that great German mic and am. However, if along the way something comes along to help bridge the gap, why not take advantage of that. Take a look at it, the specs and what your getting. Sure its probably an inexpensive Panasonic diaphragm and the tube is crap, but those can be changed out and replace with better parts or not. To anyone who knows anything about this mic, any comments would be greatly appreciated. Thanks, Rich. Something went wrong. View cart for details. All Rights Reserved. User Agreement, Privacy, Cookies and AdChoice Norton Secured powered by Verisign.

<http://churchoftheresurrectionacc.com/images/callister-materials-science-and-engineering-an-introduction-7th-edition-solutions-manual.pdf>

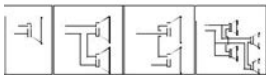
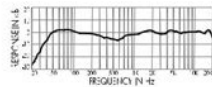

CARVIN

<https://climatechange-news.com/images/callister-rethwisch-solutions-manual.pdf>



<https://inclinedigital.com/wp-content/plugins/formcraft/file-upload/server/content/files/162738dd31291b---bristan-tulsa-shower-manual.pdf>

<AVE-FRANCE.COM/pics/files/800xa-engineering-manual.pdf>

<https://www.becompta.be/emploi/bosch-washing-machine-wfk-2401-manual>